

# ADVR-16

## ***Universal Hybrid Analog-Digital Voltage Regulator Operation Manual***

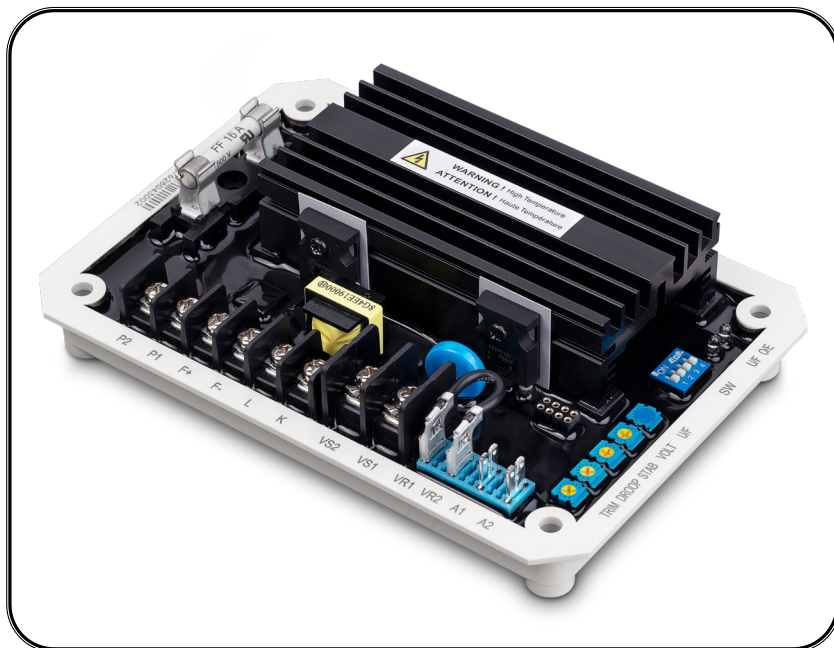

Self Excited 16 Amp Analog / Digital Voltage Regulator  
for use in 170 – 510 Vac brushless generators  
with paralleling compatibility



**KUTAI ELECTRONICS INDUSTRY CO., LTD.**

TEL : +886-7-8121771

FAX : +886-7-8121775

Website : [www.kutai.com.tw](http://www.kutai.com.tw)

Headquarters : No.3, Ln. 201, Qianfu St., Qianzhen Dist., Kaohsiung City 806037, Taiwan



---

## SECTION 1 : SPECIFICATION

### Sensing Input (VS1, VS2) Average Reading

Voltage	170 – 510 Vac, 1 phase 2 wire DIP switch setting
Adjustment	170 – 260 Vac, @ 220 Vac 340 – 510 Vac, @ 440 Vac
Frequency	50/60 Hz (DIP switch setting)

### Power Input (P1, P2)

Voltage	60 – 300 Vac, 1 phase 2 wires
Frequency	40 – 60 Hz

### Excitation Output (F+, F-)

240V 1 phase Continuous	63 Vdc 16A Max. 90 Vdc 20A for 10 secs.
Resistance	Min. 4 ohms Max. 100 ohms @220V
Fuse Spec.	Fast blow 6.3 x 32mm 16A

### External Voltage Adjustment (VR1, VR2)

Max. +/- 10% @ 1K ohms 1 watt potentiometer

### Quadrature Droop Input (K, L)

CT 1A or 5A greater than 5VA (DIP switch setting)  
Sensitivity +/- 7% @ PF +/- 0.5 (Droop adjustable)

### Analogue Voltage Input (A1, A2)

Input resistance greater than 2K Ohm  
Input range +/- 5 Vdc or 0 – 10 Vdc  
Sensitivity 1 Vdc for 5% Generator Volts  
(Trim adjustable)

### Build Up Voltage

5 Vac 25Hz residual volts at power input terminal

### Soft Start Ramp Time

3 seconds +/- 10%

### Voltage Regulation

Less than +/- 0.5% ( with 4% engine governing )

### Typical System Response

Less than 20 milliseconds

### EMI

Built-in Harmonic suppression

### Static Power Dissipation

Max.4 watts

### Under Frequency Protection (Factory Presets)

50 Hz system knee point at 45 Hz

60 Hz system knee point at 55 Hz

### Over Excitation Protection

Excitation Voltage 88Vdc +/- 10% @ power input 220Vac  
Inverse-time curve. This function can be turned off.

### Voltage Thermal Drift

Less than 3% at temperature range -40 to +70 °C

### Under Frequency Knee Point Thermal Drift

Less than +/- 0.1 Hz at temperature range -40 to +70 °C

### Environment

Operating Temperature	-40 to +70 °C
Storage Temperature	-40 to +85 °C
Relative Humidity	Max. 95%
Vibration	5.5 Gs @ 60 Hz

### Dimensions

162.0 (L) x 112.0 (W) x 43.0 (H) mm

6.38 (L) x 4.41 (W) x 1.69 (H) inch

### Weight

510 g +/- 2%

1.125 lb +/- 2%

## SECTION 2 : OUTLINE DRAWING

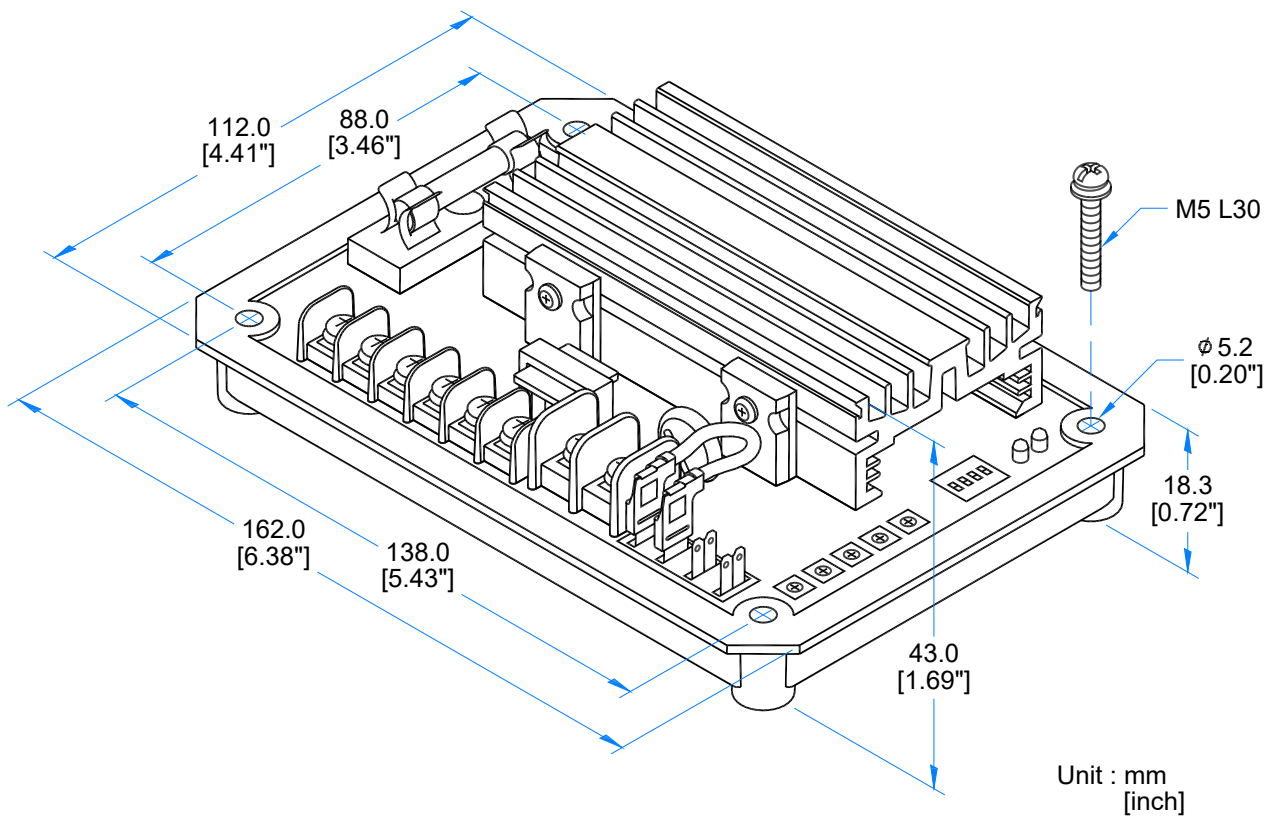
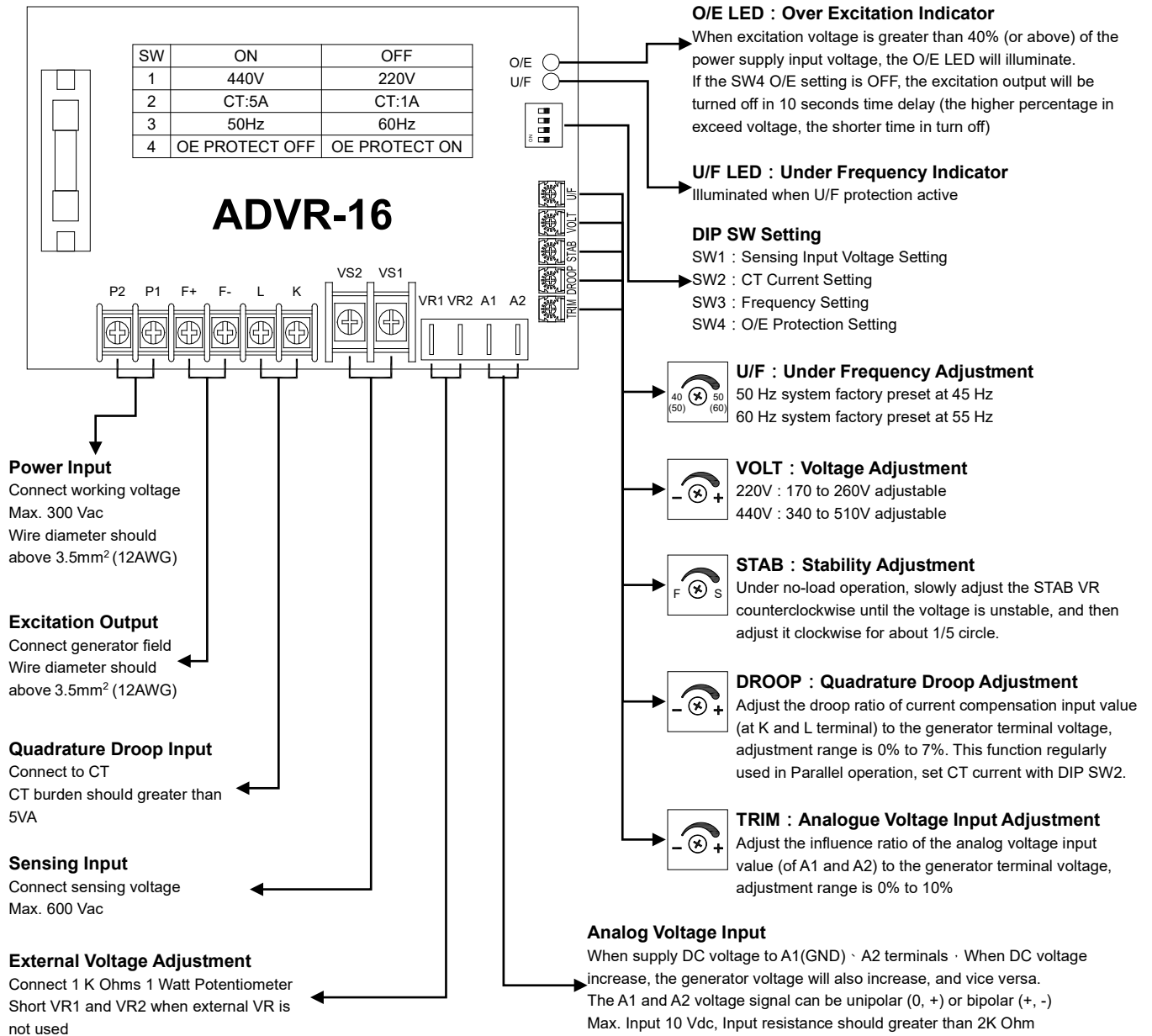

Figure 1 Outline Drawing

### ATTENTION!!

1. AVR can be mounted directly on the engine, genset, switchgear, control panel, or any position that will not affect operation. For dimension reference, please see Figure 1.
2. All voltage readings are to be taken with an average-reading voltmeter Meggers and high-potential test equipment must not be used. Use of such equipment could damage the AVR.
3. Secure all wiring connection. Do not install AVR at a place with high vibrations to prevent loose connections. For safety do not touch the heat sink while in operation.

## SECTION 3 : DIP SWITCH SETTING & VR ADJUSTMENTS



### ATTENTION!!

1. Improper setting of Under Frequency Protection could cause the output voltage of the unit to drop or become unstable under with changes in load. Avoid making any changes to the U/F setting unless necessary
2. Turn off O/E Protection when AVR in paralleling operation
3. Terminal : "Fast-On" terminals 6.35mm (1/4 inch) & With 4mm crimping terminal.
4. The connection wire for VR1, VR2 and A1, A2 must be shielded wire, the grounding wire of shielded wire should be as close as possible to the AVR, it's suggested to directly lock it on AVR mounting screw.

## SECTION 4 : WIRING CONNECTIONS

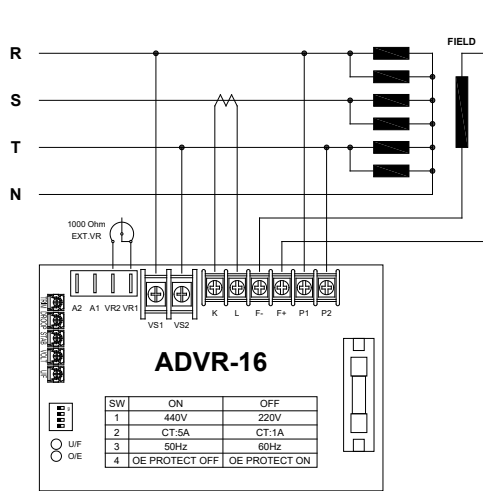

Figure 2 Self-Excited (SHUNT) 220 Vac

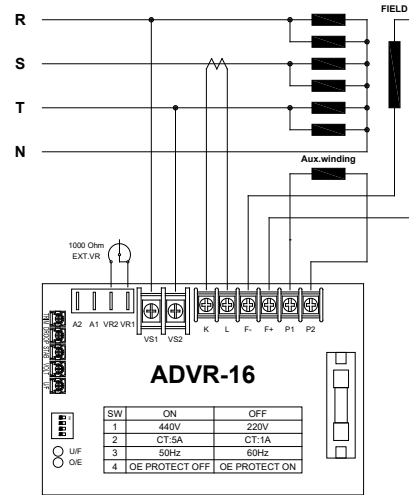

Figure 3 Auxiliary Winding 220 Vac

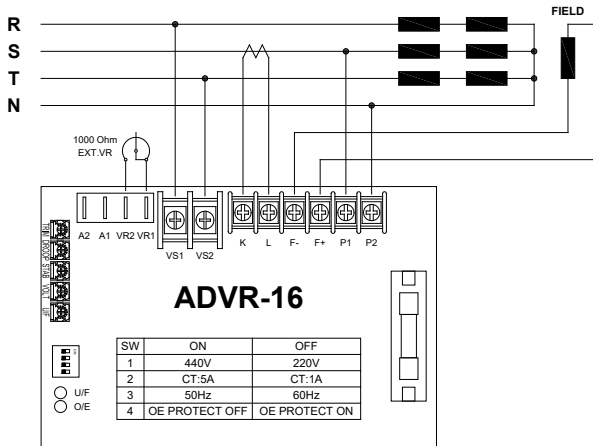

Figure 4 Self-Excited (SHUNT) 440 Vac (Power Input with Neutral Phase)

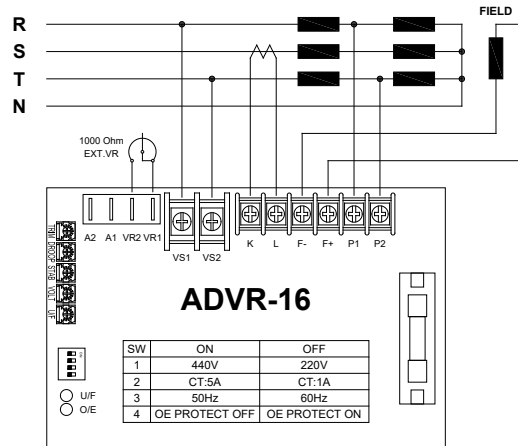

Figure 5 Self-Excited (SHUNT) 440 Vac (Power Input with parallel star connection)

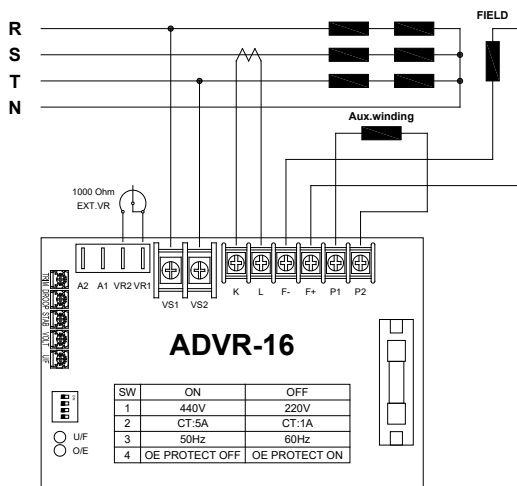

Figure 6 Auxiliary Winding 440 Vac